

SURVEY IN A WATER RESOURCE MANAGEMENT PROJECT OF AN UNDERGROUND RIVER IN INDONESIA

Levantamentos geodésicos para um projeto de gerenciamento de recursos hídricos num rio subterrâneo da Indonésia

GÜNTER SCHMITT AND MARTIN VETTER

Geodetic Institute

Universität Karlsruhe (TH)

Schmitt@gik.uni-karlsruhe.de

ABSTRACT

The district of Gunung Kidul in the Yogyakarta Special Province in middle Java is known as one of the poorest regions in Indonesia. One of the essential reasons is the acute water scarcity during the dry season. This karst area is composed of hundreds of networked caves. Due to these cave structures there is a total exchange of the surface run off and an infiltration through wide branched underground flow systems. Since 2003 the Federal Ministry of Education and Research (BMBF), Germany, is funding an interdisciplinary pilot project at the University of Karlsruhe comprising a water resources management in one of the caves, Gua Bribin. The basic idea is a partial damming up of the underground water flow by means of a barrage with an integrated micro hydro power plant. The main objective of the project is a strongly increased water supply of the population combined with a general improvement of the living conditions especially in the dry season. The paper describes, in addition to the interdisciplinary aspects of the project, the geodetic contribution, the surveying work and the data processing. The single topics are the basic survey for the installation of the drilling and the underground construction site, the control measurements for the vertical drilling of the shaft of 100 m depth, the surveying of the cave geometry in detail (1,5 km length) and the presentation of the cave within a three dimensional model as the basis for further applications such as navigation through the cave, simulation of constructions, special calculations (for example profiles and volumes) etc. The paper ends with an

outlook to a new project under application concerning a comprehensive water resources management in the whole region, in the frame of a new research funding program of the BMBF.

1. PROJECT SURVEY

1.1 Background

The District of Gunung Kidul in the Yogyakarta Special Province is supposed to be one of the poorest regions in Java and the whole of Indonesia. One of the essential reasons is the acute water shortage during the months of the dry season. On the fissured karst soil the harvest in agriculture is poor and the drinking water supply is strongly impaired. As a consequence of the poor living conditions the most active people of the population are migrating away and the regions development is stagnating. The karst area at the south cost of Java is internally composed of hundreds of networked caves, in which the quickly oozing away surface run off is collected. These flow systems finally end up as natural springs at the coastline.

On the one hand, it is necessary to improve the living conditions of the Gunung Kidul population during the dry seasons. On the other hand, the existing diesel pumping systems for the water supply should be shut down because of economical and ecological reasons. To realize both objectives, the installation of an underground water reservoir is aspired, using appropriate technologies and regenerative energies. The intention is to use the underground water resources by partially damming up the water flow by means of a barrage with an integrated micro hydro power plant (figure 1). A feasibility study supported by the Federal Ministry of Education and Research (BMBF) found the cave Gua Bribin in the region of Wonosari as suitable for a pilot project (Nestmann and Oberle 2002). The cave guarantees a storage volume of roughly 400.000 m³ with a minimal available flow of 2000 l/s during the dry season and a potential water height after damming of about 15 m.

Figure 1: Schematic section through the cave and the barrage



1.2 Joint project structure and partners

The joint project, funded by the BMBF from 2003 to 2005 under the name “Water Resources Management of an Underground River in a Karst Area, Yogyakarta Special Province, Indonesia” shall realize the targets under the condition of appropriate technologies. The necessary interdisciplinary approach involved the fields of hydraulic engineering, water management, geodesy, geochemistry, material engineering as well as timber engineering – all represented by institutes of the faculty of Civil Engineering, Geo- and Environmental Sciences of the Universität Karlsruhe (TH). One additional partner comes from the Universität Gießen, responsible for socio-economic studies and the industrial partners are the firms Herrenknecht AG, Schwanau, with the sub project “Vertical drilling machines for karst”, KSB, Frankental, with the sub project “Appropriate turbine and pumping technologies” and Walcher Wasserkraft with the sub project “Steering and regulation techniques”.

The essential partners on the Indonesian side are the government of the Yogyakarta Special Region, several ministries and authoritative institutions, state and private universities in Yogyakarta, Bandung, Solo and Jakarta and the local speleological club. The central industrial partner is the firm Wijaya Karya, Jakarta, which is responsible for all construction activities inside and outside the cave. Further informations can be found in Nestmann and Oberle (2006) and in the internet under BMBF-joint-project : <http://www.hoehlenbewirtschaftung.de> .

2. GEODETIC SUB PROJECT

2.1 Object in view

The general task of the joint project implicated a geodetic sub project, which should be responsible to make geometric fundamentals available to several other sub projects by geodetic activities. The most important target within the whole project was the destination of the drilling point on the surface, from which the shaft of 2,5 m diameter should be brought down to the cave in 100 m depth. The staking out should be within an accuracy of 20 cm for the break through point, because the shaft was planned at the border of the cave. Such a border position guaranties a convenient entrance to the cave without hindering any construction activities.

The conception was to look at Gua Bribin as a demonstration cave in which different strategies of energy production and water supply should be studied respectively simulated. Because the tightness of the karst has been estimated critically three different variants have been discussed :

- partial damming of the water flow system by a reinforced concrete dam with an integrated micro hydroelectric power plant,
- energy production for water supply through the construction of a weir and pressure pipeline,
- energy production for water supply through a cascade of weir systems with open channel flow.

All these variants require an extensive planning, for which a complete three dimensional measurement of the cave with a sufficient accuracy was necessary. As result of this survey a three dimensional model of the cave has been produced, which allows a virtual flight through the shaft and the complete cave up to the old entrance.

2.2 Conception

At the Geodetic Institute in Karlsruhe (GIK) different tests have been carried out to choose the measurement techniques, with which the postulated accuracies might be realized in a rational way. An important criterion was to analyse the reliability, that means the possibility of detecting gross errors in the observations.

Techniques such as compass or gyro measurements were dropped out because of low accuracy and to long measurement duration. Because in the cave it can be mostly worked with tripods, a polygon simulation has been carried out (see fig. 2). The polygon covered in the design phase a length of about 3 km with 65 points and a shortest distance between two points in the critical cave entrance area of only 3,5 m. The analysis with the GIK software package NETZ2D (Oppen and Jäger 1991) brought as result, that an independent double measurement was necessary to fulfil the postulations, when a tachymeter is used with an accuracy of 2 mm for the distances and 0,6 mgon for the directions, supposing a centring accuracy of 0,5 mm. Therefore a tachymeter Leica TCR 1102 was elected for these measurements.

2.3 Further works

Additional tasks resulted partly during the progress of the project. The precise underground course of the cave was transferred into the existing topographical maps after corresponding measurements with GPS handheld receivers. The geographical coordinates of the cave entrance and the drilling point were estimated and those of several prominent points such as street crossings as pass points. The firm Herrenknecht developed in the frame of the project a new vertical drilling machine. For this machine was at first no effective navigation technique available. Therefore a simple and cheap method was developed at the GIK which guarantees the vertical navigation of the machine over a depth of 100 m with an appropriate accuracy.

Figure 2 : Polygon design

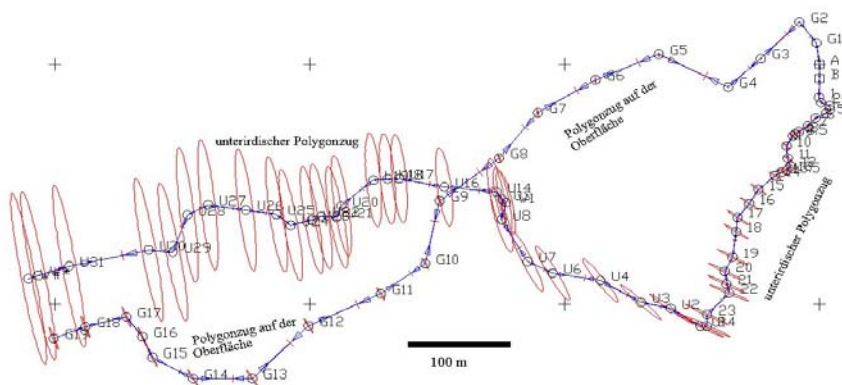

3. DETAILED SURVEY OF THE CAVE

3.1 Main purpose

During the campaign in 2003 a detailed three dimensional survey of the cave was carried out as the basis for the production of a spatial model. The cave is divided into a 1,7 km long course with the actual river and a 300 m long entrance, connecting the main course with the surface (fig. 3). The main course is closed at both ends by a siphon. In the main course of the cave near the entrance a weir is located, which has been constructed by the Indonesian administration.

Figure 3 : Course of the cave Gua Bribin



The spatial model region of the cave is beginning at the existing weir and follows the river course over a distance of about 1 km and ends short before the lower cave end. Here the river is dammed up to a lake of 400 m length. The newest reconnaissance has proved that this lake after the discharge siphon is continued for further 600 m.

In the region of the planned new barrage seven cross sections have been fixed. Additionally several kernel drillings for geological studies have been brought down. Both the cross sections and the drilling points had to be integrated into the cave model. The underground cross sections had to be transferred geometrically to the surface. Then a well suited place for the shaft drilling had to be fixed and a number of trigonometric points for the securing of the building site had to be installed.

3.2 Implementation

The polygon points for the detailed survey in the cave could be mostly fixed by plug marks in the rock. In the middle and at the end of the cave seven special consoles were screwed in the cave walls (fig. 4). As indicated in the design phase (see chapter 2.2) two independent polygon measurements were carried out in order to secure reliability.

Figure 4 : Console measurements in the lake areas



Illumination problems in the close region could be solved by carbide helm lamps and waterproof halogen pocket lamps. For the underground construction area preliminary coordinates were calculated and transferred by the over ground polygon in the direction of the outside drilling area. In this part of the polygon also two independent measurements were carried out and adjusted. For the detailed measurements in the cave the tachymeter TCR 1102 was used in the reflector less

modus. Because of visibility problems for the observer at the instrument the single points were marked by a second person with halogen lamps.

3.3 Particularities

The high air humidity of 100 % at a temperature of 26° rendered the measurements more difficult. The covering of the instrumental optic with damp often prevented a fast measurement. For the centring of the tripods a laser plumb would be of advantage against the classical optical plumbs. Severe problems came up at points with muddy underground and at the console points, where the measurements had to be carried out standing in the water or from a rubber dinghy. Often black manganese deposits at the walls reduced the laser impulse in such a way, that a distance measurement was nearly impossible. But corresponding to the information of Leica this problem can be solved in future campaigns by using the R300 module of the new 1200-series. Additional problems came up with a high material wear of all mechanical components, with the corrosion of the radio sets etc.

3.4 Results

The final polygon existed of 12 over ground and 66 underground points. A very important result is the relative accuracy between the underground end of the polygon in the construction area and the drilling point at the surface as the end of the outside polygon (fig. 5). The calculations with the adjustment software NETZ2D proved a relative error ellipse with semi axes of 19,5 cm in lateral direction and 1,6 cm in longitudinal direction. It follows that the drilling point at the surface can be traced out so, that with a probability of about 40% the deviation from the break through point in the underground is less than 20 cm.

Figure 5 : The polygon

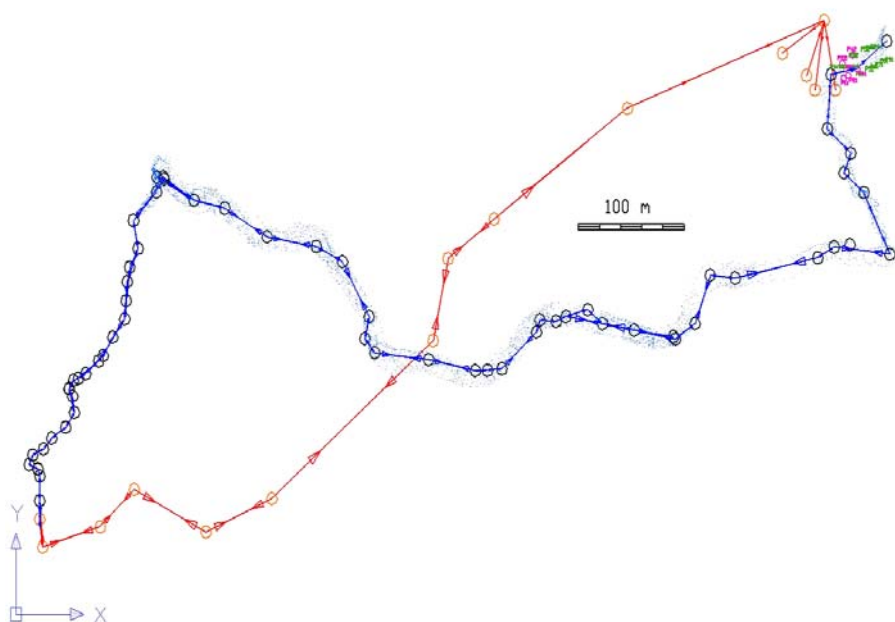

For the three dimensional modelling of the cave altogether 5500 single points were measured. In comparison : This amount of points corresponds to more than 500 cross profiles over a cave length of 1 km, if one profile is existing of about 10 points.

4. TECHNICAL SURVEYS

4.1 Fixing the shaft point

After Gua Bribin had been chosen as experimental cave and after first recognitions and measurements it came out that for the construction of the barrage, the material transport and the future maintenance of the installations a shaft at the end of the cave to the surface is indispensable. Concept and results of the polygon measurements for the connection between the underground construction site and the surface have been explained in the previous chapter.

The Indonesian administration constructed a new access road to the construction site in the middle of the hilly country. The project coordinators decided the following concerning the exact position of the drilling shaft. The centre of the shaft should lie 0,5 m out of the cave in one of the profiles, with a radius of 1,25 m it

should have an overlapping with the cave of only 0,75 m. This position was marked out on the construction site in order to concrete the starting shaft for the vertical drilling machine VSM 2500 of the firm Herrenknecht (fig. 6).

Figure 6 : Vertical drilling machine VSM 2500



4.2 Shaft drilling

The drilling of a vertical shaft was a completely new ground for the firm Herrenknecht, wherefore no experiences concerning the steering of the machine during the drilling were available. Therefore at the GIK a concept was developed - once more taking into consideration appropriate technologies – under the principle to be simply to maintain and to be as cheap as possible. After thorough studies it was decided to use laser plumbs of the firm Leica, normally used for the centring of tripods, and to install screen targets on the machine (fig. 7). Additionally the machine operator had a big circular bubble to control the verticality of the 13 m high drilling machine (fig. 8).

Figure 7 : Screen target



Figure 8 : Circular bubble



To control the movements of the machine in an optimal way, two laser plumbs and two corresponding targets were needed. The plumbs were installed on steel girders in the foundation after the machine was working completely in the underground. The situation of the plumbs was estimated by tachymetric measurements from the points of the local network on the construction site. The biggest problem was the fact that the lasers are normally used for short distances up to 3 m, but here up to 50 m depth. Both the levelling of the plumbs and the precise estimation of the foot points had to be carried out very careful. Over a height difference of 50 m the laser point has a blurred form of about 6 cm diameter and describes a circle around the exact foot point because of the remaining non-verticality, if the plumb is turned, from which the centre is representative. The whole depth of the shaft amounts to 100 m, what means that the whole construction had to be removed down, after the drilling had reached a depth of 50 m. Despite of all difficulties this simple and cheap system has proved extraordinary. The break through difference in the cave compared with the starting position at the surface was only 1,4 cm and 7 cm. After the completion of the shaft the accuracy of the polygon system and the marking out could be controlled finally by a plumbing over the whole 100 m. It came out that the difference between the measurements inside and outside the cave amounted only to 2,1 cm in both coordinate directions. That means that both dead polygons with nearly 80 points over a total length of 3 km had a deviation at the ends of less than 3 cm, a result which exceeded all expectations.

4.3 Building axes and deformation network

The construction area in the cave lies in a lake which is discharging by a siphon into another big lake. Therefore it was necessary to construct blocking dams in order to drain the working area. It was necessary to signalize several building axes for further outbreak and concreting works. All the axes of the planning have

been transferred to the cave walls and marked by special screws. The construction is still lasting and should be finished in 2006.

An additional task was the installation of a network of control points for a future deformation surveying of the barrage. This was realized by special screws with plastic spheres in the cave ceiling. By tachymetric measurements from the existing consoles the coordinates of these eight points could be estimated with an accuracy of better than 1 mm. So the assumptions for future deformation measurements are given.

5. PRODUCTION OF THE 3D-MODEL

The three dimensional survey of the cave was carried out with reflector less distance measurements (see chapter 3.4) with a point cloud of about 5500 single points. This can be compared in principle with a 3D terrestrial laser scanning, the principle difference is the distance between the measured points, which lies in the order of magnitude of several meters instead of a few cm. The advantage of a small expenditure in hardware and time lead necessarily to a very rough recording of the geometry of the cave and to severe complications during the data processing with software packages principally outlined for laser scanning data. The use of a laser scanner was not taken into consideration because of the extreme climatic conditions of nearly 100% air humidity, under which a faultless operating of the scanner technique could not be guaranteed.

5.1 Triangular meshing

After the elimination of errors in the data material, the point cloud was brought to a triangular meshing in order to generate more or less automatically a 3D surface model. Two different software concepts have been applied, the so called two dimensional meshing with the product Autodesk Land Desktop and a three dimensional meshing with the software Wrap from the firm Geomagic. Wrap has been written for the data processing of laser-scanning point clouds mainly. The problem of great distances within the point cloud requires sometimes the use of the one or the other software. So for example the modelling of continuous shells for the floor and the ceiling using a two dimensional meshing was realized with Land desktop. On the contrary, for big pillars a three dimensional meshing was preferred which is connecting both shells together, a technique which is not to recommend for the whole cave because of discrepancies between point distances in the same shell and between the two shells, leading to an incorrect meshing. In such cases the manual correction takes more time than the time which is saved by a completely automatic meshing. The hybrid use of both systems is therefore the best processing technique in the present constellation.

Figure 9 : Model of the existing weir

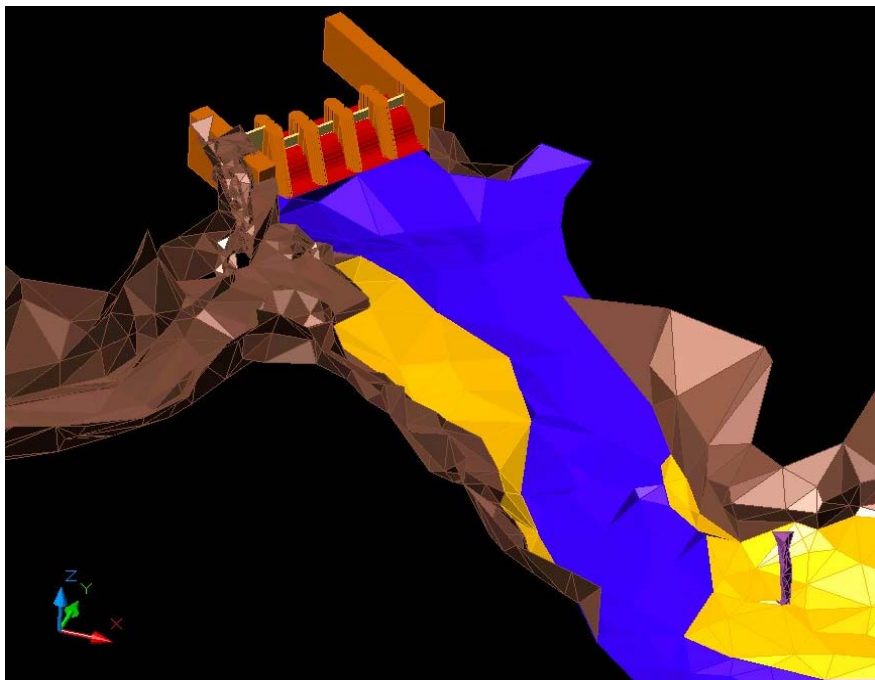

5.2 Modelling

All together it can be stated that an automatic generating of a 3D-model is still insufficient, a big part of the corrections of incorrect meshing was done using AutoCAD Map. In addition to these problems the existing weir in the upper part of the cave and the planned installations at the lower end had to be modelled and to be integrated. This modelling was realized by use of the clear geometrical forms of the installations (see fig. 9 and 10). The entire three dimensional model of the cave and the artificial constructions could then be used for any further analyses.

Figure 10 : Planned barrage with micro power plant and access shaft

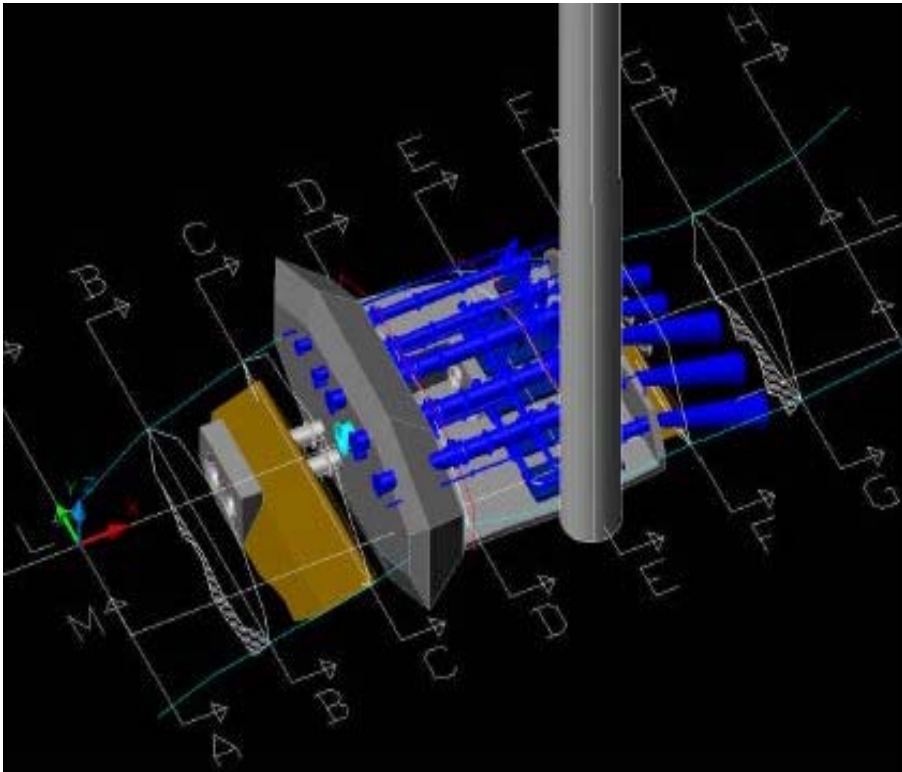

5.3 Visualisation

The software Discreet 3D Studio Max (version 5) was used for presentation and simulation purposes. This software allows to import existing models in DXF format and to visualise them. The program has indeed functions for modelling and treating bodies in the three dimensional space, but it is suited more for a free hand modelling than for working with fixed geometrical constraints. Therefore it is in the most cases more clever from the geodetic point of view, to import the complete model and to do the pure visualisation with this software. The visualisation potential is extremely extensive. Nevertheless the model has to be partitioned first in single objects, because most of the functions can be applied only to elements such as points, lines, surfaces etc. These objects can be derived during the import directly from layers or colours of the CAD-model. As functions for example materials can be attributed to the objects. These materials must not only represent colours or bitmaps, it can be worked also with shadows, transparency, reflections,

brilliance and many others more. For the visualisation such an attribution of materials is not sufficient. The model has to be illuminated individually by light sources, otherwise it remains during the rendering, the proper visualisation, in the dark. This perspective is fixed by the occasional position of a camera.

In order to get movements and not only standing pictures, it is possible to animate not only the model objects but also the camera itself. The animation of the camera is made possible for example by flying through or over the model, the objects can be moved by animation relatively to each other. In the visualisation of the cave so called particle effects can be useful, with which flowing water, damp or smoke can be simulated. The work on the visualisation of the model of Gua Bribin in Indonesia is not yet completed.

6. OUTLOOK

After the successful break through of the shaft drilling in December 2004, the construction works have been initiated since the end of the rainy season in the springtime of 2005. Geological, geotechnical and water leakage studies near the underground construction site promise a successful damming up of the cave. Hopefully the whole installation can be put into operation in the year 2006.

In the meantime the ministry BMBF has initiated a new research program : integrated water resources management (IWRM) including a technology and know how transfer (capacity building). The partners of the running project, intensified by capacity from the Research Centre Karlsruhe (FZK), took part at a competition of ideas. They will present a new proposal "IWRM for the region middle-Java in Indonesia" (see Oberle et al. 2005) with the following targets :

- reconnaissance of water resources in the karst region their development with regenerative and sustainable technologies,
- improvement and optimization of the partly existing water supply system,
- development of appropriate water preparation and waste water technologies,
- installation of effective GIS-based Water management tools and
- socio economical and political realization strategies.

The geodetic sub project in preparation will be concentrated on the installation of a spatial information system (GIS), open for all project partners, and on a general survey-technical attendance of the whole project.

ACKNOWLEDGEMENT

The authors thank the BMBF for the financial support of this project and the project partners for the excellent cooperation.

LITERATURE

- NESTMANN, F. AND P. OBERLE (2002): Erkundung und Grenzen der Wasser- und Energie Bewirtschaftung großer unterirdischer Wasservorräte in Wonosari, Yogyakarta, Java, Indonesien. Feasibility study by order of the BMBF, *Institute for Water Resources Management, Hydraulic and Rural Engineering*, Universität Karlsruhe (TH).
- NESTMANN, F. AND P. OBERLE (2006): Erschließung und Bewirtschaftung unterirdischer Wasservorkommen in Karstgebieten auf Java, Indonesien. Fridericiana, *Journal of the Universität Karlsruhe (TH)*, Heft 65 (in preparation).
- OBERLE, P., KAPPLER, J. AND B. UNGER (2005): Integriertes Wasserressourcen-Management (IWRM) in Gunung Kidul, Java, Indonesien. Final report for the feasibility study in order of the BMBF, *Institut für Wasser und Gewässerentwicklung*, Universität Karlsruhe (TH).
- OPPEN, S. AND R. JÄGER (1991): Das Softwarepaket NETZ2D. Mitteilungen des DVW-Landesvereins Baden-Württemberg 38, 190-209.
- BMBF Verbundprojekt : <http://www.hoehlenbewirtschaftung.de>.

Recebido em março / 06